

2ZMD004701xxxxx Pressure Dependent Zone Damper - Celsius

Description

The 2ZMD004701xxxxx series Pressure Dependent Zone Damper for Celsius operation consists of a round air damper, zone controller, and actuator. An optional auxiliary relay board (2ZRE0047000024) is available for control of auxiliary heat and/or control of series or parallel flow fan terminal units.

The Zone Controller (2ZC0047000124) is microprocessor based and communicates with the Zone Manager on the Meridian network communications loop. The Zone Controller monitors the space temperature and allocates the proper airflow into its assigned space to achieve the desired comfort and ventilation levels.

Pressure Dependent Zone Dampers are used in air conditioning systems that do not require pressure independent airflow control. If your system requires pressure independent control of the airflow, see the "2ZMD004701xxxxx series - Pressure Independent Zone Damper - Celsius" data sheet for the correct specifications.

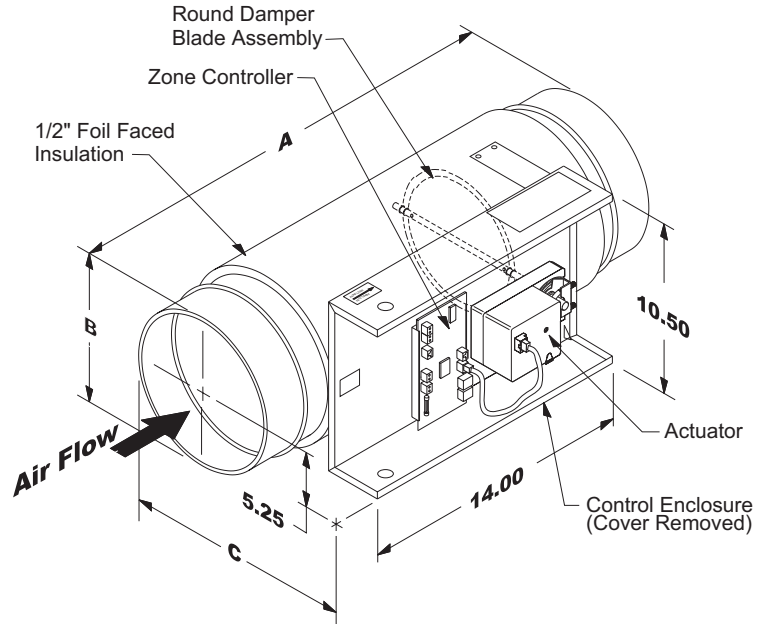

All Zone Dampers are tested and certified in accordance with ARI standard 880. An ARI label is affixed to all units.

Mounting

The Zone Damper assembly should be mounted according to standard duct installation practices with airflow direction as shown in the illustration above. After installation of the Zone Damper in the ductwork, insulation should be applied around any remaining uninsulated surface on the air valve inlet and outlet. The Zone Damper should be mounted so the control enclosure is positioned to the left or right side of the ductwork with the control enclosure in a vertical plane. Do not mount the Zone Damper Assembly with the control enclosure on the top or bottom of the ductwork. Adequate clearance should be maintained between the control panel and any obstruction to allow for removal of the control panel cover and access to the controls.

Technical Data		2ZMD00471xxxxx Pressure Dependent Zone Damper - Celsius			
Zone Controller:		Air Damper Construction:			
Supply Power	24 Volt AC	Damper Body	24 Ga. Galv. Steel		
Power Consumption	12 VA Maximum	Damper Blade	Round -18 Ga. Galv. Steel		
Operating Temperature	17°C to 52°C	Damper Bearings	Oil Impregnated Bronze		
Operating Humidity	90% RH Non-Condensing	Damper Seal	Volara® Type A Gasket		
Communications	RS-485 - 9600 Baud	Leakage	Less Than 1% @ 3" SP		
		Insulation	½" Foil Faced Fiberglass		
Inputs:		Dimensions:			
Room Temperature Sensor		Air Damper Model	"A"	"B"	"C"
Setpoint Adjustment		2ZMD0047010624 (6")	19.00	5.88	9.38
Actuator Position Feedback		2ZMD0047010824 (8")	19.00	7.88	11.38
		2ZMD0047011024 (10")	19.00	9.88	13.38
		2ZMD0047011224 (12")	21.00	11.88	15.38
		2ZMD0047011424 (14")	21.00	13.88	17.38
		2ZMD0047011624 (16")	21.00	15.88	19.38
Outputs:					
Expansion Port for Auxiliary Relay Board					
Actuator Port for Connection to Damper Actuator					
York reserves the right to change specifications without notice					
Three Year Warranty On Electronic Components			One Year Warranty On Air Damper		

Zone Damper Sizing

Use a load program to determine the peak load for each zone. These calculations will be used to select Zone Damper sizes.

The Meridian Systems utilize a typical low pressure duct design. To reduce noise problems, duct pressures should not exceed 1" W.C.

Primary trunk ducts used with Meridian systems should not be "undersized". This is especially true of "pressure dependent" systems. With larger trunk ducts, it is easier to assure relatively constant pressure to each Zone Damper. Runs should be as short as possible, and the trunk duct system kept as symmetrical as possible to facilitate system balancing. Wherever possible, run the trunk ducts above corridors and locate the Zone Dampers above corridors to reduce the noise in the space and facilitate service of the valves. Trunk ducts should be sized for no more than 0.1" W.C. drop per 100 ft. of duct, and a maximum duct velocity of 2000 FPM.

Using the maximum acceptable velocity for a branch duct (typically 1000-1500 FPM for minimal noise), find the smallest Zone Damper that will deliver the required CFM as determined by the load program.

2ZMD004701xxxxx Pressure Dependent Zone Damper - Celsius

Locate the branch velocity used in the duct design program in the left hand column of the Zone Damper Selection Data table. Move across the table and find the Zone Damper which will provide the acceptable CFM to meet the zone airflow requirements.

Note: Compare the Zone Damper size selected against the duct size to determine if the next size up or down will provide acceptable performance without requiring a transition fitting.

Up to a maximum of two Slaved-Zone Dampers may be slaved together with the main Zone Damper for large zones. This design should be reserved only for situations when it is not practical to use a single Zone Damper. See the Slaved-Zone Damper specification sheet for information regarding application and selection of Slaved-Zone Dampers.

Zone Damper Selection Data						
2ZMD004701xxxxx Pressure Dependent Zone Damper - Celsius						
Zone Damper Round Duct Size (Area Ft²)	6" (0.188)	8" (0.338)	10" (0.532)	12" (0.769)	14" (1.050)	16" (1.375)
Velocity Through Zone Damper FPM	Airflow Through Zone Damper - CFM (ΔPs inches W.C. w/ Damper Full Open)					
500	94 (0.01)	169 (0.01)	266 (0.01)	385 (0.01)	525 (0.01)	687 (0.01)
750	141 (0.03)	254 (0.02)	399 (0.01)	577 (0.02)	788 (0.01)	1031 (0.01)
1000	188 (0.05)	338 (0.03)	532 (0.02)	769 (0.03)	1050 (0.02)	1375 (0.01)
1250	235 (0.07)	423 (0.04)	665 (0.03)	961 (0.04)	1313 (0.03)	1718 (0.02)
1500	282 (0.09)	507 (0.06)	798 (0.04)	1154 (0.05)	1575 (0.04)	2062 (0.03)
1750	329 (0.12)	592 (0.08)	931 (0.06)	1346 (0.06)	1838 (0.05)	2405 (0.04)
2000	376 (0.15)	676 (0.10)	1064 (0.07)	1538 (0.07)	2100 (0.07)	2749 (0.05)

York reserves the right to change specifications without notice